

The **UniFlare™ UFO range** is a compact range of elevated landfill gas flares for small to medium sized landfill sites having a combustion temperature of 850 to 1000°C, depending on gas quality. The high temperature stainless steel flare tip together with the condensate knockout pot, gas fan and control panel are all mounted on a compact robust galvanized chassis all pre-assembled for immediate use.

Ideally suited for temporary pumping trials or permanent installation the **UniFlare™ UFO range** provides an economical, safe and efficient gas control flare.

SPECIFICATION

The standard motor is ExN IIT3 rated 415 volts 3 phase 50 Hz
Galvanized steel condensate knockout vessel complete with an inspection and cleaning port.
HDPE condensate drain lance and liquid seal vessel.

Compact Gas Flare

Burner	High temperature stainless steel
Burner shroud	High temperature stainless steel
Combustion range CH ₄	20-60 % vol.
Flame temperature*	850 - 1000 °C
Combustion control	Manual gas/air mixer
High energy spark ignition	
Flame monitoring	
UV sensor	
Gas regulating and isolating valves	
Flame arrester	
Fail safe to close safety valve	
High condensate switch	
Low pressure switch	

Chassis & Pipe work

Gas sampling and instrument ports
Welded to EN287-8
Galvanized to BS 729

Control panel

Enclosure to IP65
Star-Delta or soft start (except for 1.5kw motor which is DOL)

Options

Automatic temperature controlling thermocouple
Multiple inlet manifold
Gas fan inlet flame arrester
Condensate knockout system, trace heating and insulation
Pumped drainage system
Gas analyser to measure CH₄, CO₂, O₂,
Flow meter with manometer read-out
Data logger
Telemetry
Acoustic enclosure
Higher pressure gas fans with pressure control for utilisation projects.
Security plant enclosure
Diesel or diesel-electric powered gas exhauster
Extended shroud to hide visible flame
Other capacities to 3000 Nm₃ h⁻¹

*The temperature is dependent on the gas quality and section of flame monitored.
Should the gas quality be lower than 25% then the temperature may be less than 850°C.

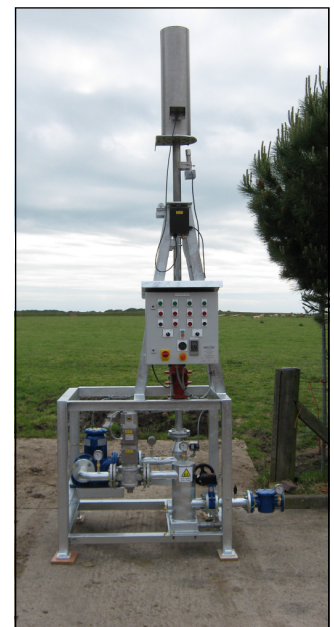

UFO SPECIFICATION & DIMENSIONS

Model		UFO-100	UFO-300	UFO-400	UFO-500	UFO-600	UFO-1000
Landfill gas flow	Nm ³ /hr	20-100	60-300	80-400	100-500	120-600	200-1000
Motor size	kWe	1.5	4	7.5	11	11	18.5
Max power consumption	kWe	1.25	3.0	4.5	6.0	7.0	7.3
Blower max pressure	mbar	100	100	120	120	120	120
Noise level (15m @2m high dB(A))		68	69	70	70	70	70
Height	metre	3750	4250	4250	4250	4250	4950
Width	metre	1500	1500	1500	1500	1500	2200
Length	metre	2000	2500	2500	2500	2500	3000
Weight	Kg	600	800	900	1200	1250	2800
Suction inlet	DN	80	80	100	100	150	150

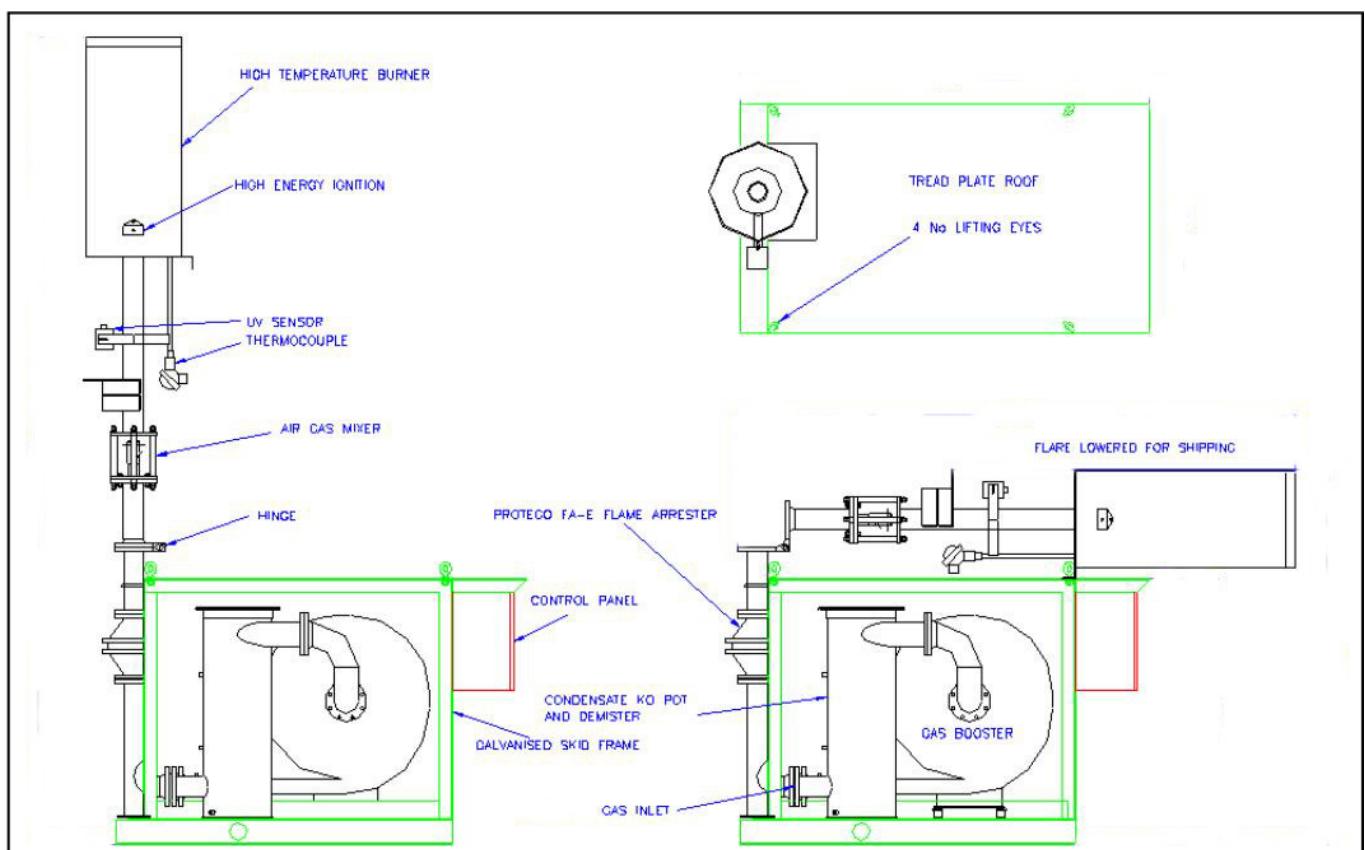

Specifications may be changed without prior notice

Uniflare Limited, Unit 19 Runway Farm Technical Park, Honiley Road, Kenilworth CV8 1NQ, Warwickshire, England
 Tel : +44 1676 529118 Fax : +44 01676 529119
 Email : enquiries@uniflare.co.uk
 Web : www.uniflare.co.uk

